

HOUSE LEAD DETAIL FOR 4" DIA. PLASTIC SUMP PUMP LEADS
NO SCALE

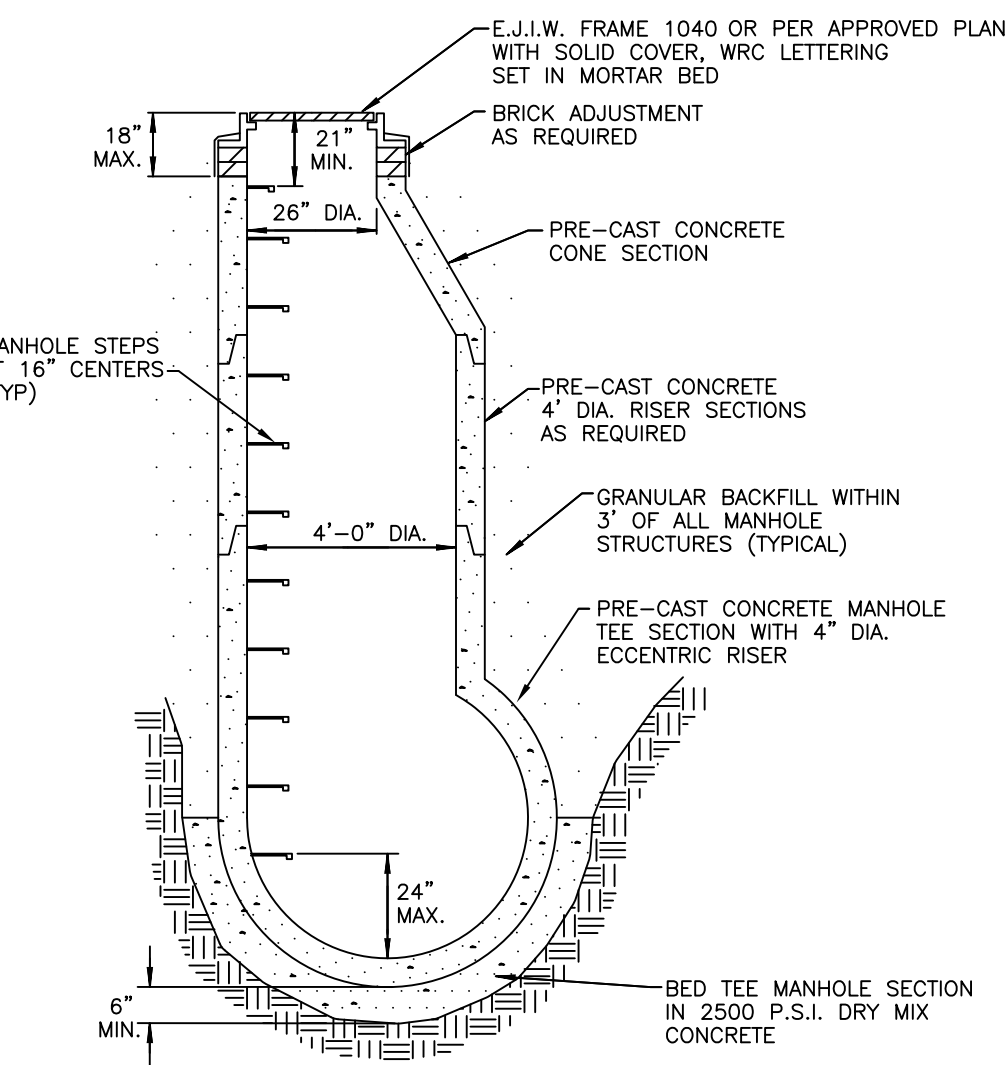

PRE-CAST TEE MANHOLE DETAIL
NO SCALE

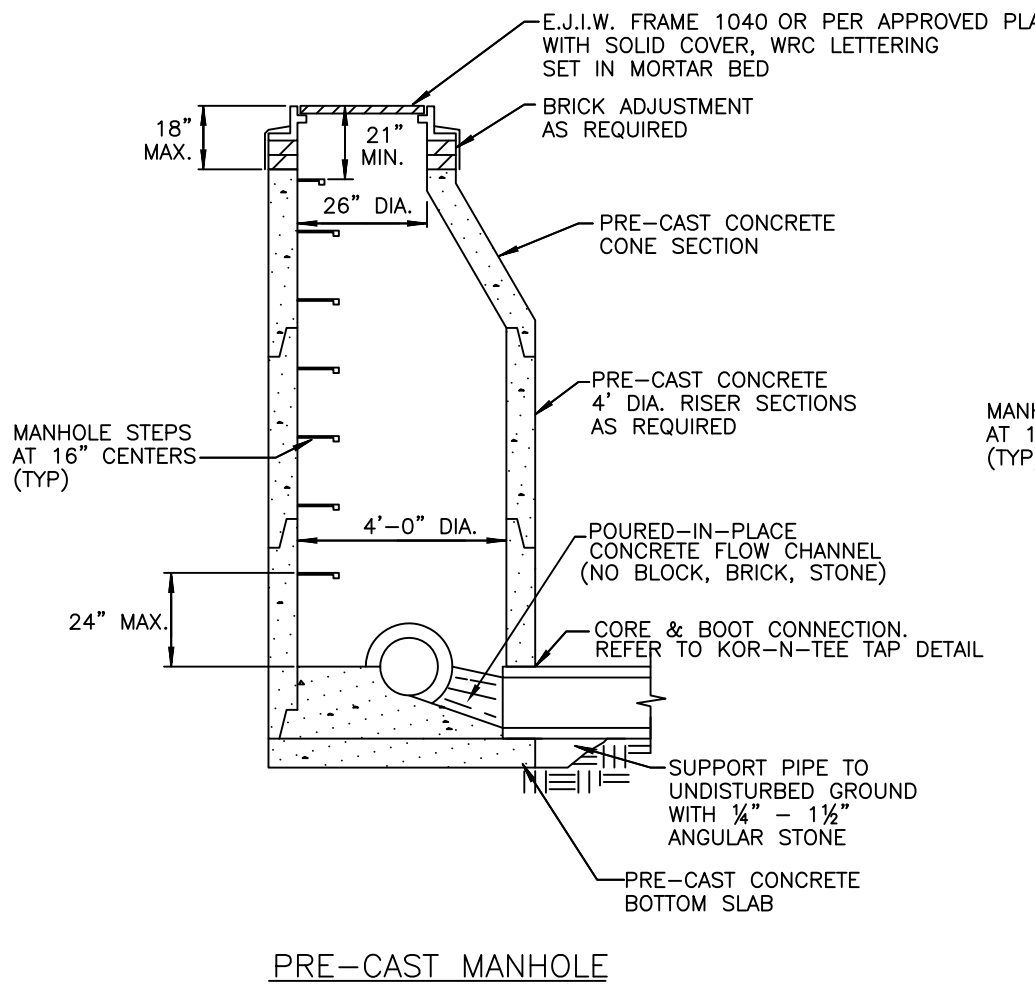

STANDARD MANHOLE DETAILS
NO SCALE

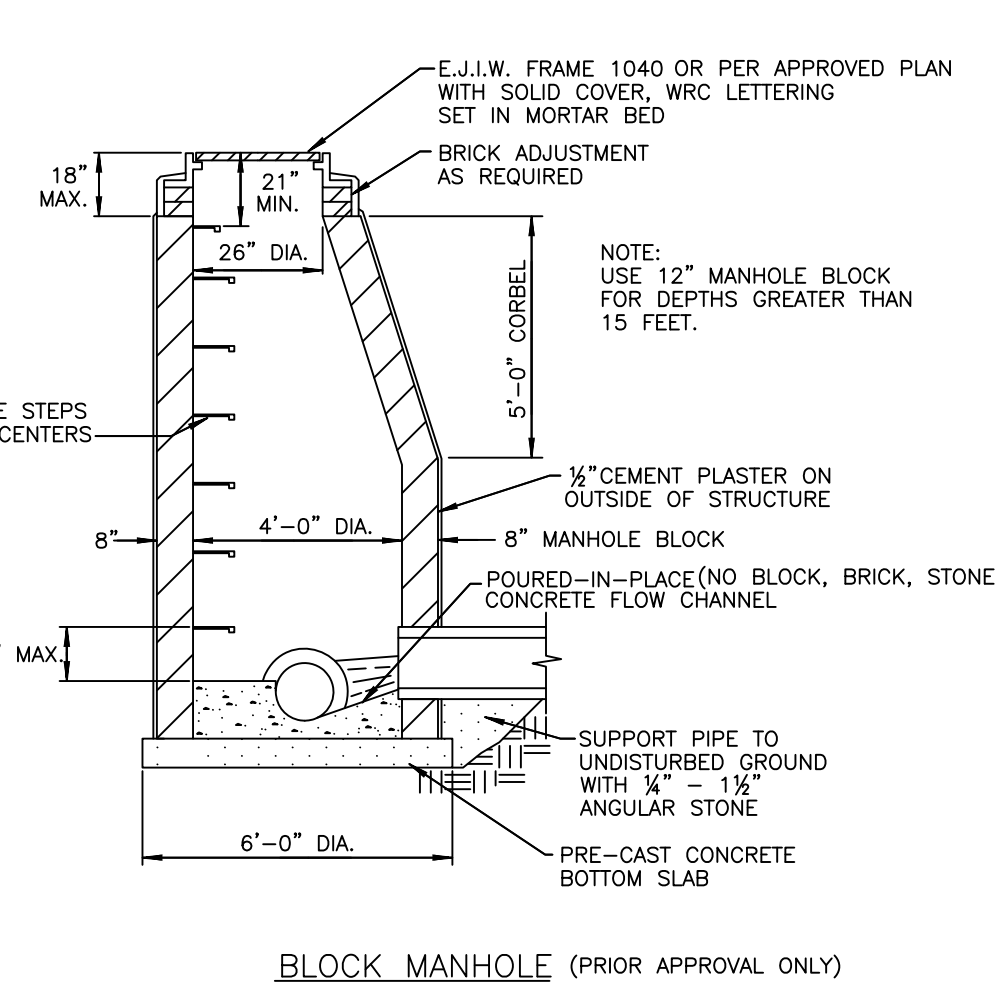

BLOCK MANHOLE (PRIOR APPROVAL ONLY)

GENERAL NOTES

- Type and class of pipe shall be as specified on plans.
- Class "B" bedding shall be used throughout, unless otherwise specified on the plan.
- All end sections 18" and larger shall be provided with a bar screen unless otherwise approved.
- Standard rip-rap shall be 8"-15" fragmented rock, heavy rip-rap shall be 16"-24" fragmented rock. (No Broken Concrete)
- MANHOLE REQUIREMENTS:
 - All new catch basins, inlets, and manholes are to be manufactured to ASTM C-478 specifications.
 - All new catch basins, inlets, and manholes shall have WRC approved flexible, watertight seals where pipes pass through walls. Manholes shall be of precast sections with modified groove tongue and rubber gasket type joints. Pre cast manhole cone sections shall be WRC approved modified eccentric cone type.
 - Taps through manhole joints or cone sections are prohibited unless otherwise approved.
 - Manhole steps to be plastic coated steel meeting the requirements in ASTM D 2146, Type II, Grade 49108, MA. Industries P.S.I. Polypropylene, (or approved equal). Steps to be installed during manhole manufacture. Place at 16" centers 45" from centerline of sewer.
 - Cone section with modified groove tongue joints and with stud inserts cast in place. Top to have flush surface.
 - ASTM C-478 riser section with modified groove tongue joints.
 - Res-seal, link-seal, press wedge II, or kor-n-tee seal block (with stainless steel korband) flexible rubber manhole joints. (or approved equal).

- CONCRETE PIPE REQUIREMENTS:
 - Concrete pipe to be per ASTM C76 standards.
 - It will be required to TV all pipe 30 days after installation.
 - The contractor shall provide reinforced concrete pipe as specified on the plans.
 - All reinforced concrete pipe shall have modified grooved tongue joints with o-ring type rubber gasket, per A.S.T.M. specifications C443.
- SUMP PUMP LEAD REQUIREMENTS:
 - All sump pump leads connected to a County Drain pipe shall be pre-manufactured.
 - Sump pump leads connected to a manhole shall be cored and booted. Refer to Kor-N-Tee Tap Detail.
 - Sump pump mains and leads shall be ABS (truss and solid wall), PVC (truss, solid wall, A2000), ADS N-12 WT with premium joints.
 - Ends of all 4" sump pump leads shall be temporarily capped and their location staked, witnessed and recorded.
 - All sump pump leads to be taken to the property line.
 - Sump pump mains must have a cleanout with a minimum inside diameter of 24" and be constructed at changes of alignment, ends of sump pump mains or as indicated on the plan.

- RESTORATION REQUIREMENTS:
 - All disturbed area within the County Drain right-of-way shall be restored as follows:
 - Under roads, sidewalks, driveways and parking areas, backfill material shall be placed loosely into trenches in six (6) inch layers with each layer compacted to not less than 95% of maximum dry density as determined by the ASTM D 1557 Compaction Standard (modified proctor compaction test). All other areas shall have each layer compacted to not less than 90% of maximum dry density.
 - Finish subgrade
 - Place 3" thickness clean topsoil acceptable to the engineer to attain finished grade. Topsoil must not be contaminated and may not be a mixture of natural underlying soils, subsoil materials, or other materials. It must consist of natural loam, sandy loam, silty loam or clay loam humus-bearing soil adapted to the sustenance of plant life. Topsoil must be neither excessively acidic nor excessively alkaline. It must be of mineral origin, exclusive of any peat or muck.
 - Apply seed and fertilizer as follows:

Location	Seeding Requirements	Fertilizer Requirement
Slopes and Ditch Banks, Etc.	M.D.O.T. "Roadside Mix" Turf Seed Mixture TOM (10% Kentucky Blue, 20% Perennial Rye, 30% Hard Fescue, 40% Creeping Red Fescue) applied at 220 lb/acre	M.D.O.T. Seeding and Sodding Fertilizers, Class A
Other Areas	M.D.O.T. "Roadside Mix" Turf Seed Mixture THM (30% Kentucky Blue, 20% Perennial Rye, 50% Creeping Red Fescue) applied at 220 lb/acre	M.D.O.T. Seeding and Sodding Fertilizers, Class A

- * Sod is required in maintained lawn areas. Refer to WRC General Specifications for additional requirements and information.
- apply straw or marsh hay mulch in an air-dry condition to all seeded areas over the surface to a uniform thickness at 2 tons/acre.
- mulch shall be anchored in place with biodegradable netting, not larger than 1 1/2" by 2" nor smaller than 1/2" by 1/2".
- the contractor shall be responsible to insure the growth of all seeded areas, and shall re-seed as necessary to accomplish this.

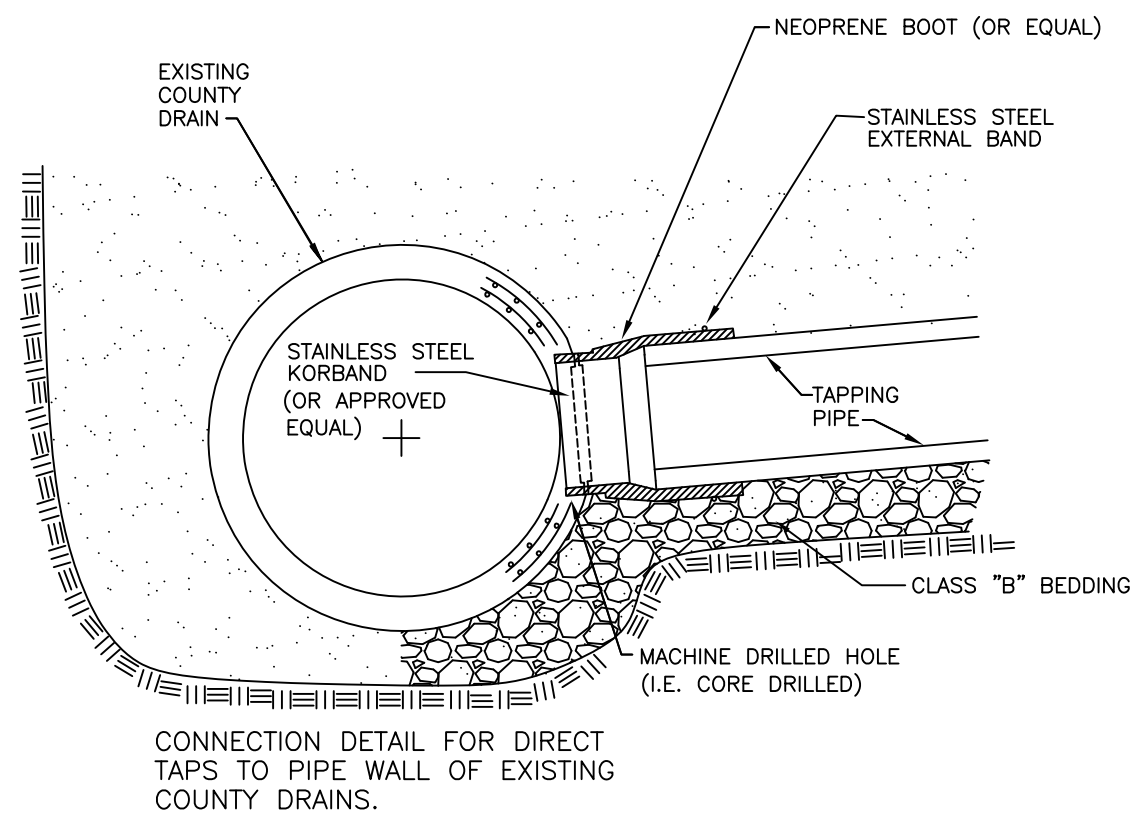

KOR-N-TEE TAP (OR APPROVED EQUAL)
NO SCALE

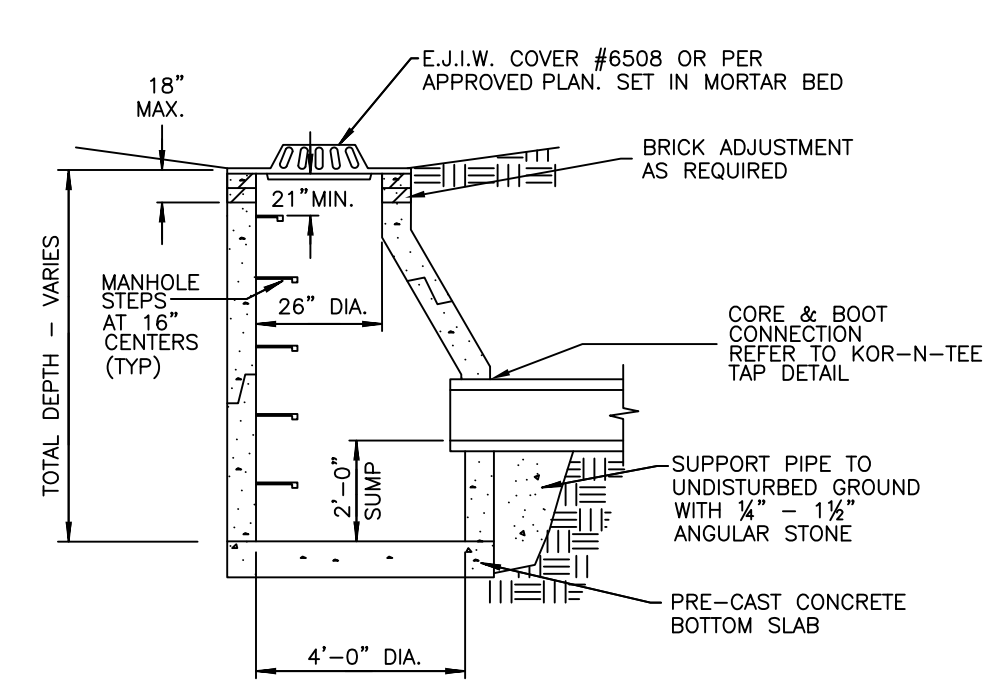

PRE-CAST CATCH BASIN DETAIL
NO SCALE

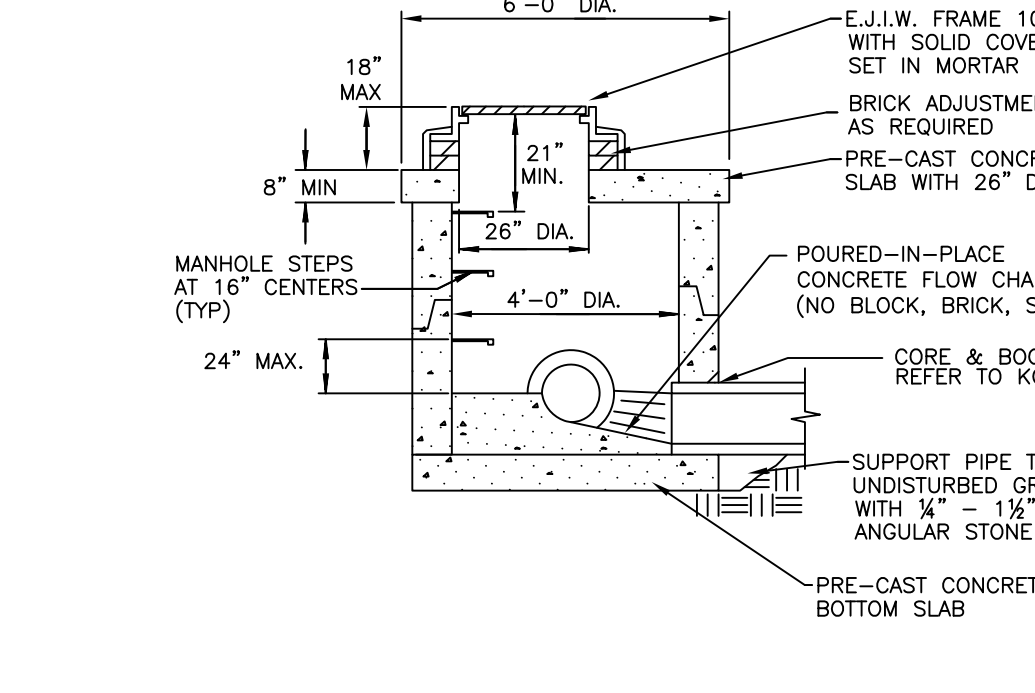

PRE-CAST LOW HEAD MANHOLE DETAIL
NO SCALE (PRIOR APPROVAL ONLY)

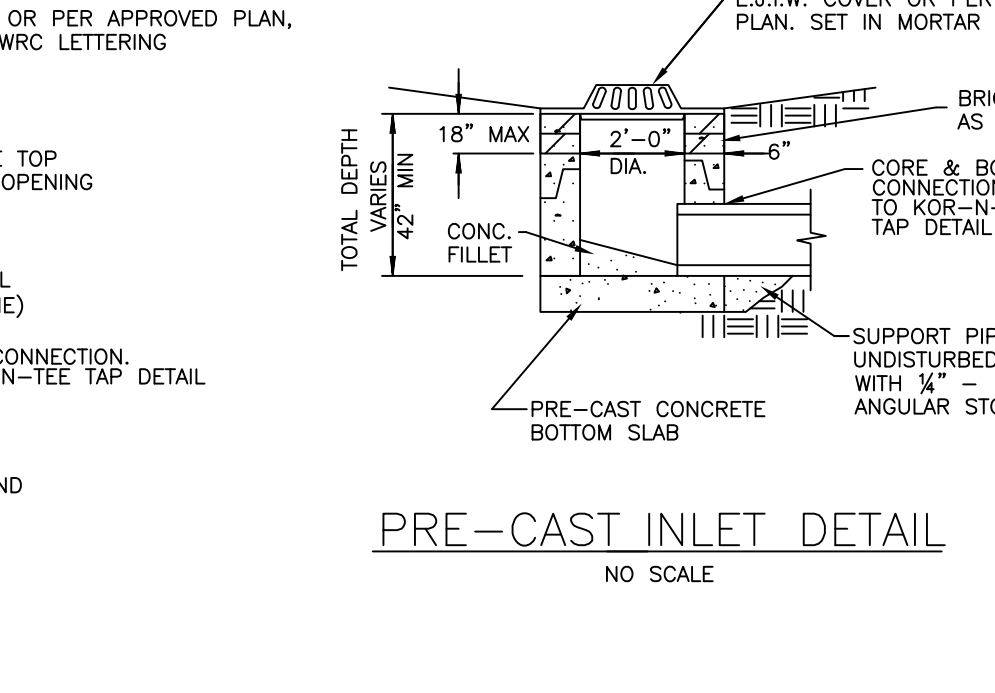

PRE-CAST INLET DETAIL
NO SCALE

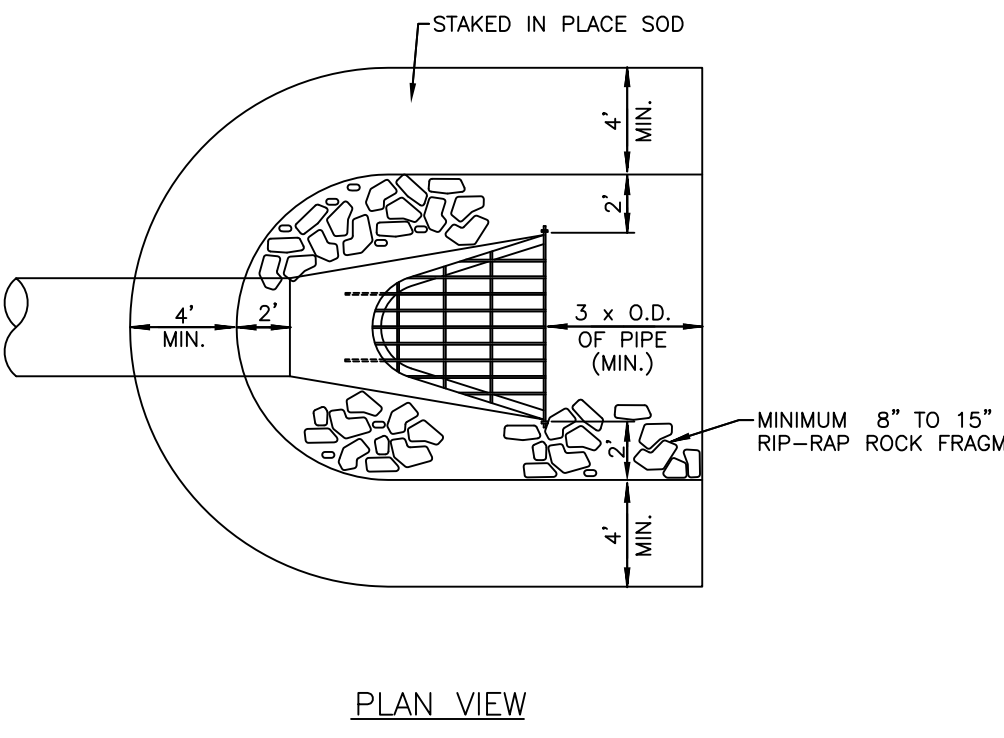

PLAN VIEW

PROFILE VIEW

END SECTION AND BAR SCREEN DETAIL
NO SCALE

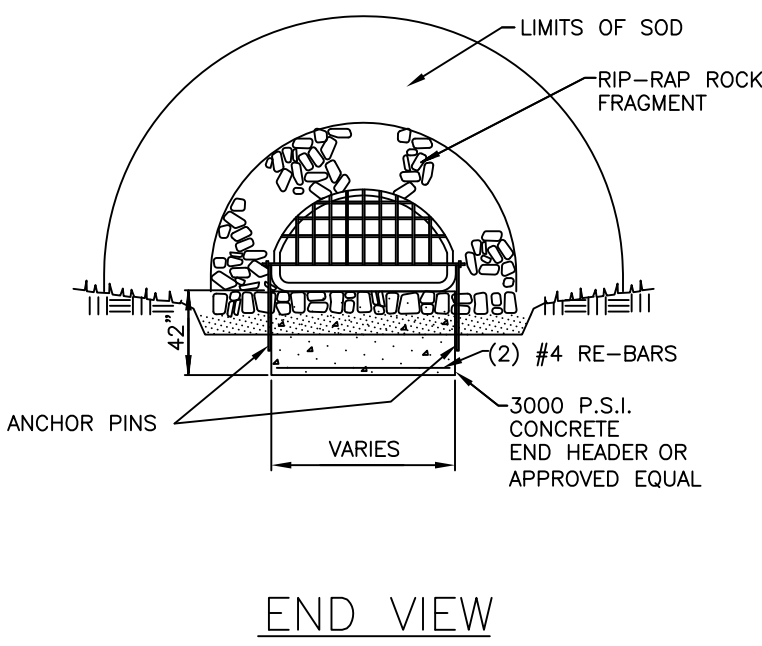

END VIEW

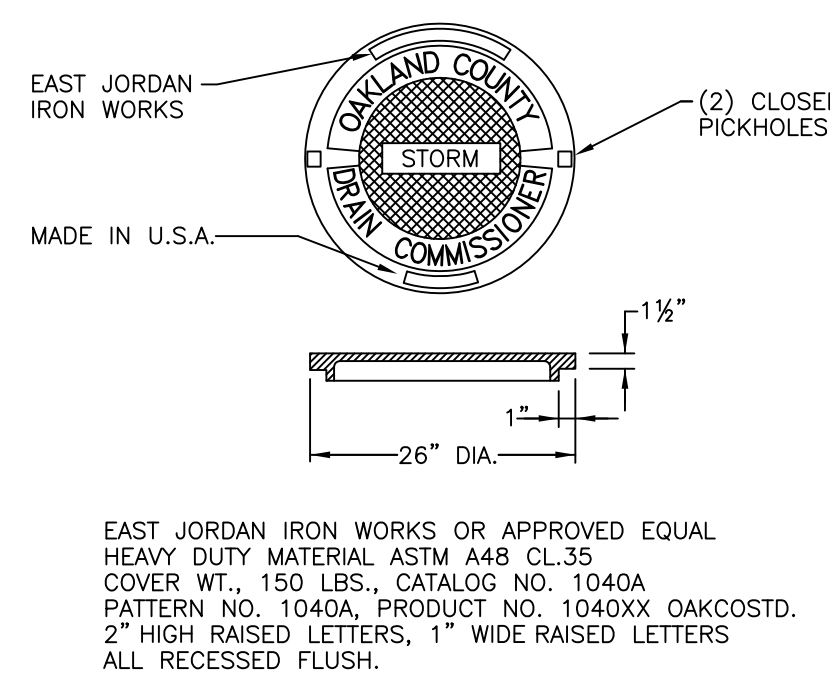

LETTERED MANHOLE COVER FOR WRC

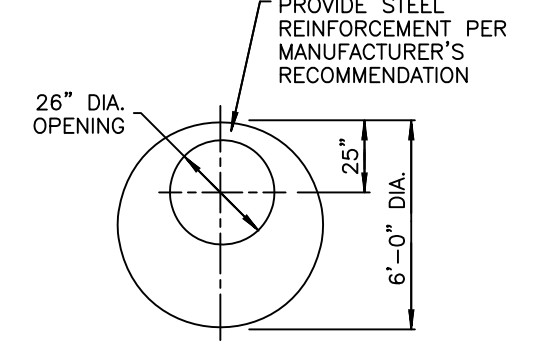

PRECAST CONCRETE TOP SLAB DETAIL

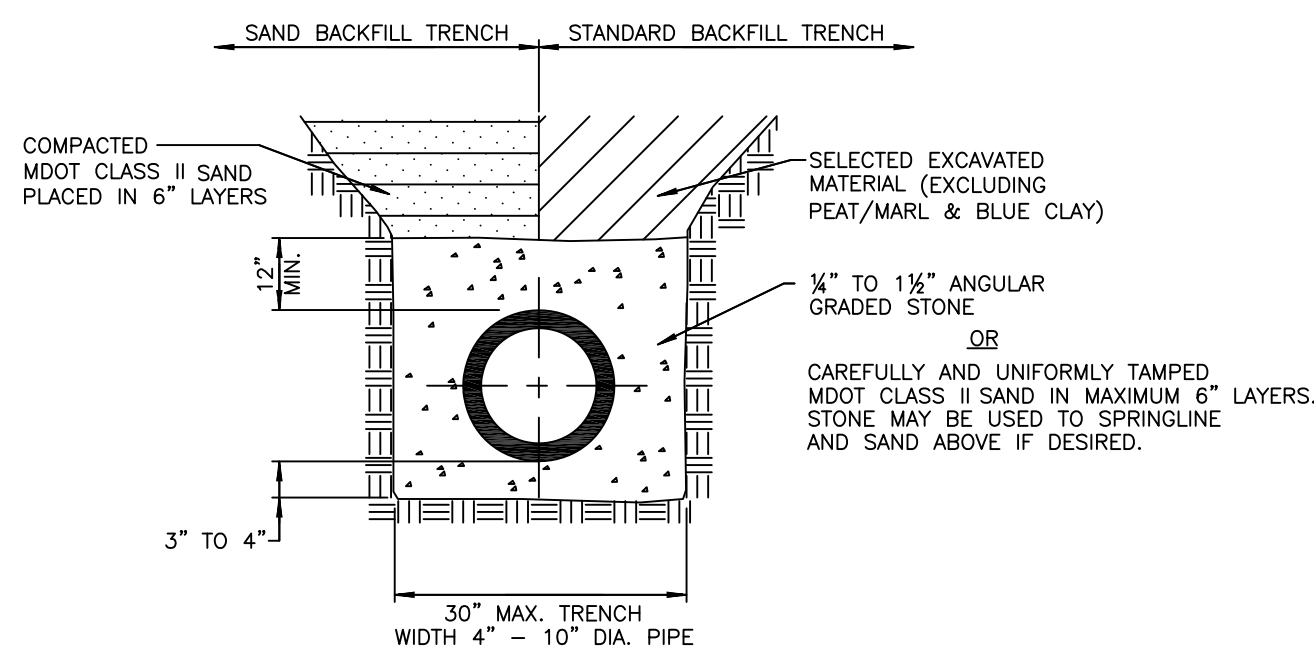

ABS (TRUSS AND SOLID WALL), PVC (TRUSS, SOLID WALL, A2000), ADS N-12 WT PIPE BEDDING DETAIL
NO SCALE

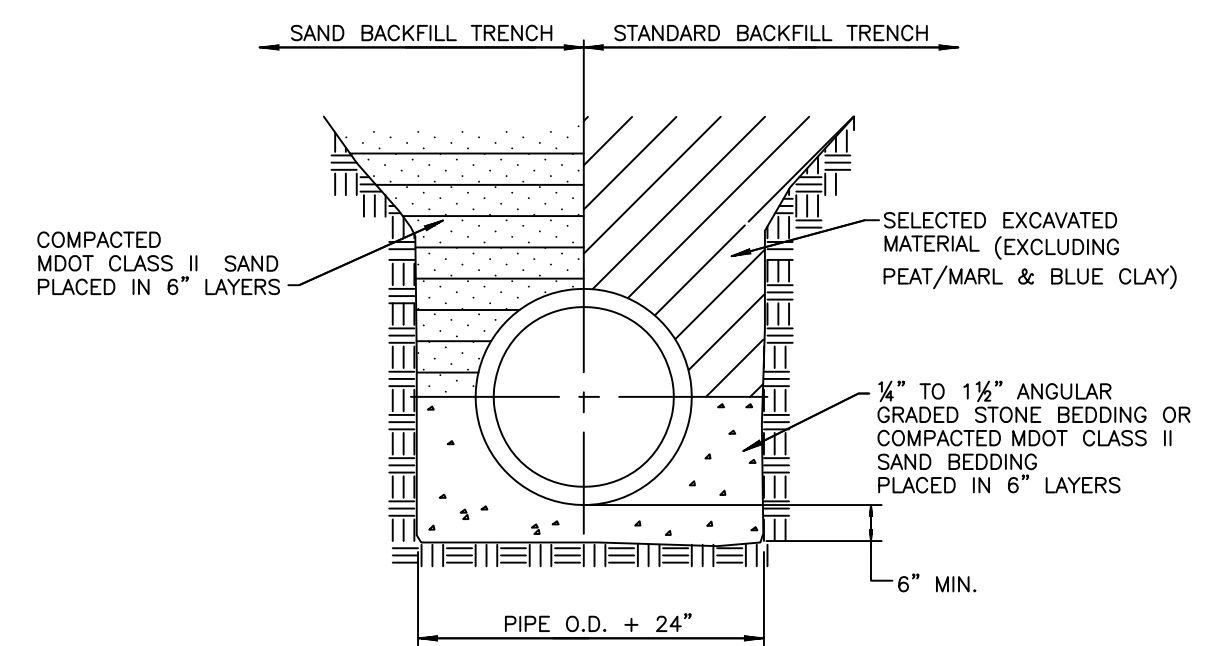

CLASS "B" BEDDING TRENCH DETAIL FOR 27" DIAMETER AND LARGER CONCRETE PIPE
NO SCALE

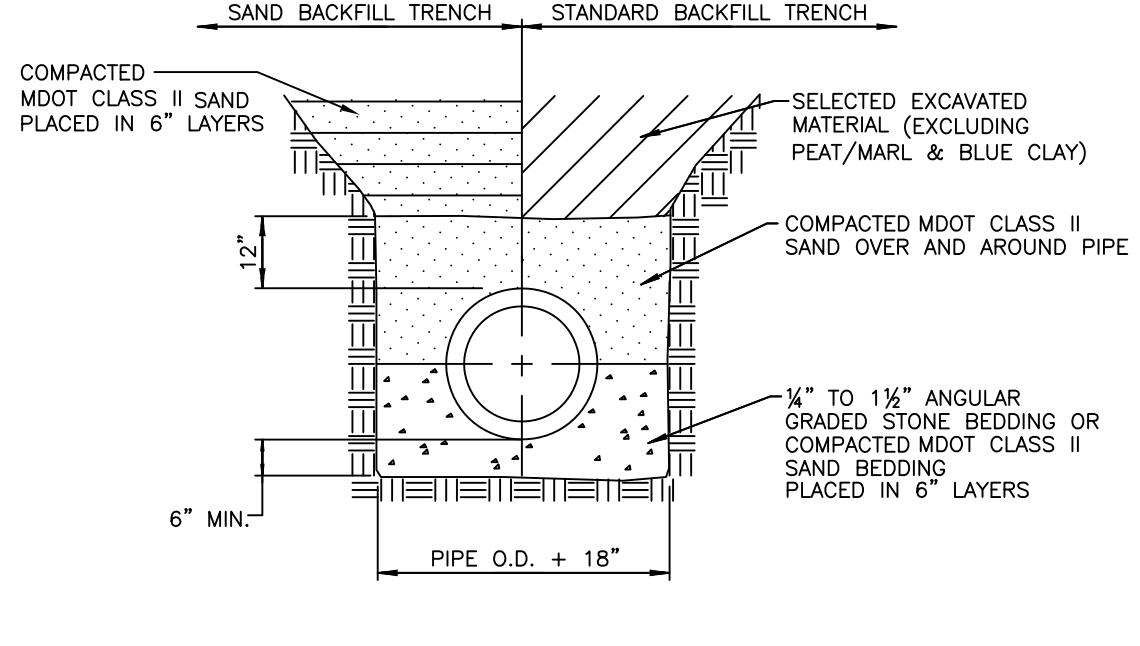

CLASS "B" BEDDING TRENCH DETAIL FOR 24" DIAMETER AND SMALLER CONCRETE PIPE
NO SCALE

STORM DRAIN NOTES AND DETAILS

Rev.	By	Date	Description
1	EL	6/17/05	MERGED PROPOSED NOTES/DETAILS TO STANDARD DETAIL. SHEET PER APPROVAL FROM STANDARDS COMMITTEE
2	EL	3/11/09	PROPOSED DETAIL CHANGES NEW LOGO
3	EL	9/12/09	APPROVAL PER STANDARDS COMMITTEE
4			

ORIG. DATE: 05/05/97
SCALE: NONE
DESIGNED BY: WRC
DRAWN BY: Mapping

WRC
WATER RESOURCES COMMISSIONER
John P. McCallister

ONE PUBLIC WORKS DRIVE, BLDG 95 WEST WATERFORD, MICHIGAN 48328-1907
SHEET NO.: 1 of 1