

MECHANICAL JOINT TAPPING
SLEEVE ONLY. LEAD JOINT
CORROSION STOP
WHERE REQUIRED

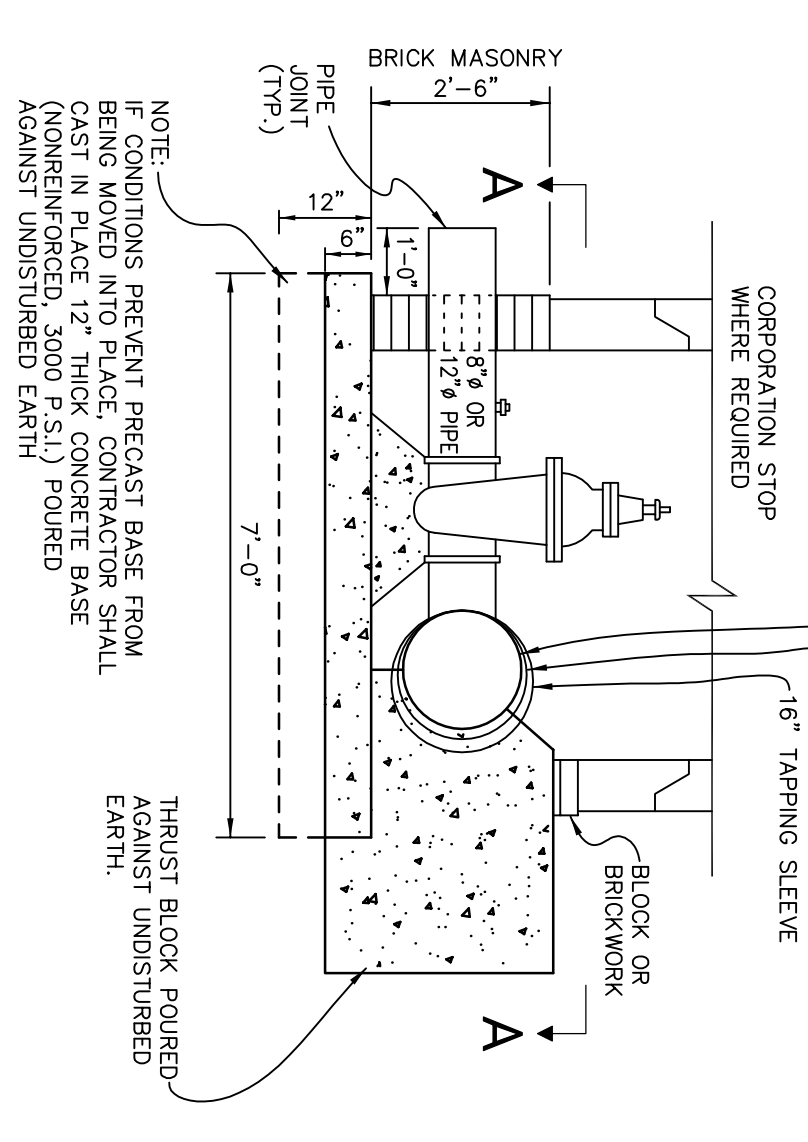

TAPPING SLEEVE, VALVE & WELL
(B-B)

HEAVY DUTY
UNIT WT.: 400 LBS., 35
MATT. ST. 48, 48, 48, 35
E.I.L.W. 1040
NEEMA R-1642

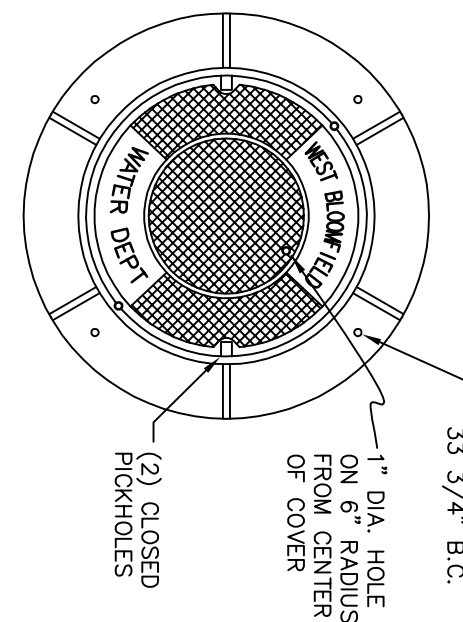

GATE WELL FRAME & COVER
(33-12-17)

ALL HYDRANTS INSTALLED SHALL BE PAINTED PRIOR TO FINAL ACCEPTANCE.
HYDROPHOBIC ACRYLIC - 2 COAT SYSTEM SPRAY APPLICATION-OVERCOAT
A. Primer: Sand & Scribe to remove loose primer & rust. Clean all visible rust to bare metal using SSPC-SP-11 power tool cleaning to bare metal. Hydrants with trisodium phosphate (TSP), to remove all dirt, grease and urine. Rinse with clean water. Hydrants must be clean, dry and free of oil, grease and other contaminants prior to priming.
B. Apply the coating of the following rates:
Coat Minimum Maximum
Primer (spot) 2.0 4.0
Intermediate (full) 2.0 3.0
Topcoat (full) 2.0 3.0
Total 6.0 10.0
All over spray to be removed by wiping or power washing.
Apply in temperatures between 32°-100°F & surface temperature is at least 5° above dewpoint.
D. The contractor should be advised that the owner or owner's representative will take all readings on the exterior per SSPC-PA2, which requires gauge adjustment from magnetic plane to peak plane.
E. Paint shall be Rust-Oleum Industrial Enamel Fire Hydrant Red 7400 system #210492. Primer shall be a compatible Rust-Oleum primer.

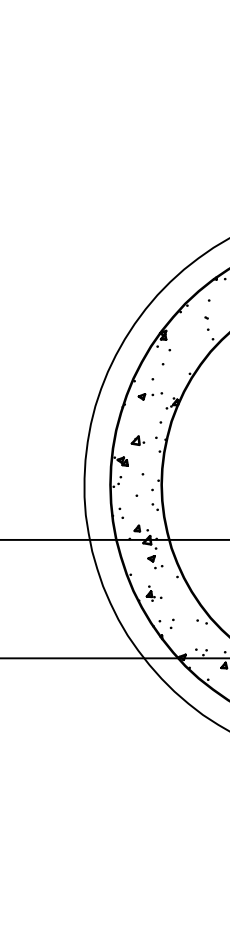

PLAN TAPPING SLEEVE, VALVE & WELL - TYPICAL
(A-A)

HYDRANT PAINTING SPECIFICATIONS

PIPE BARREL SUPPORT FOR WATERMAIN
CONSTRUCTED IN CASING
(33-03-24)

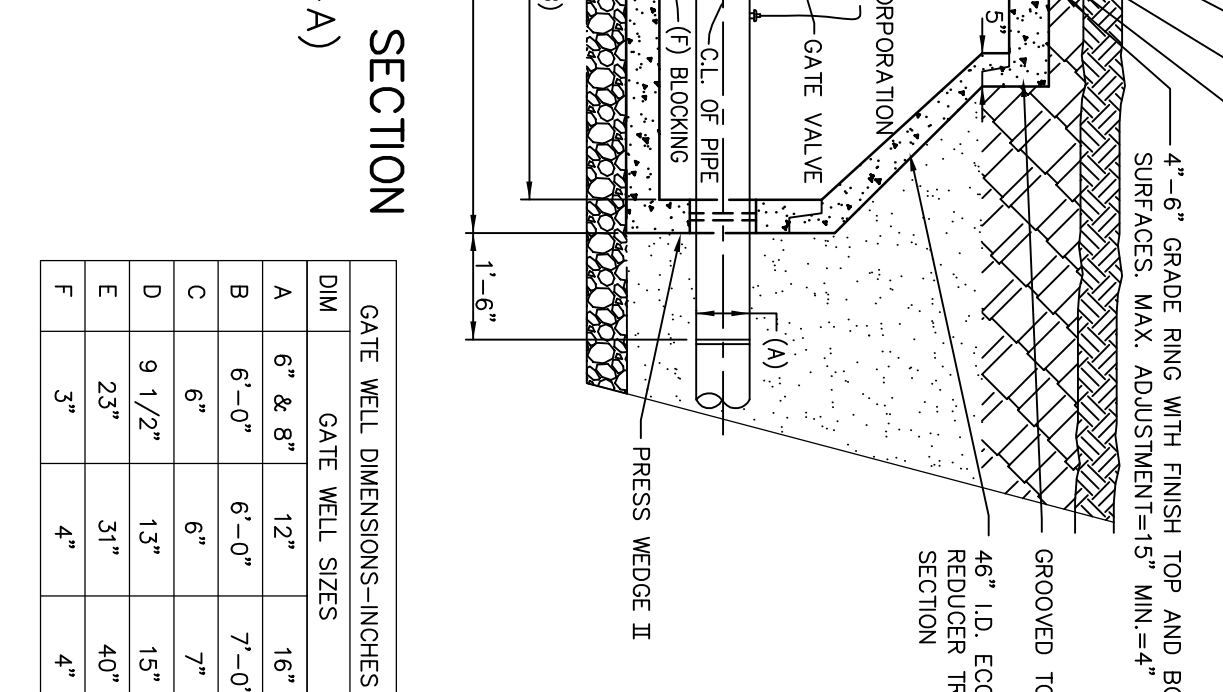
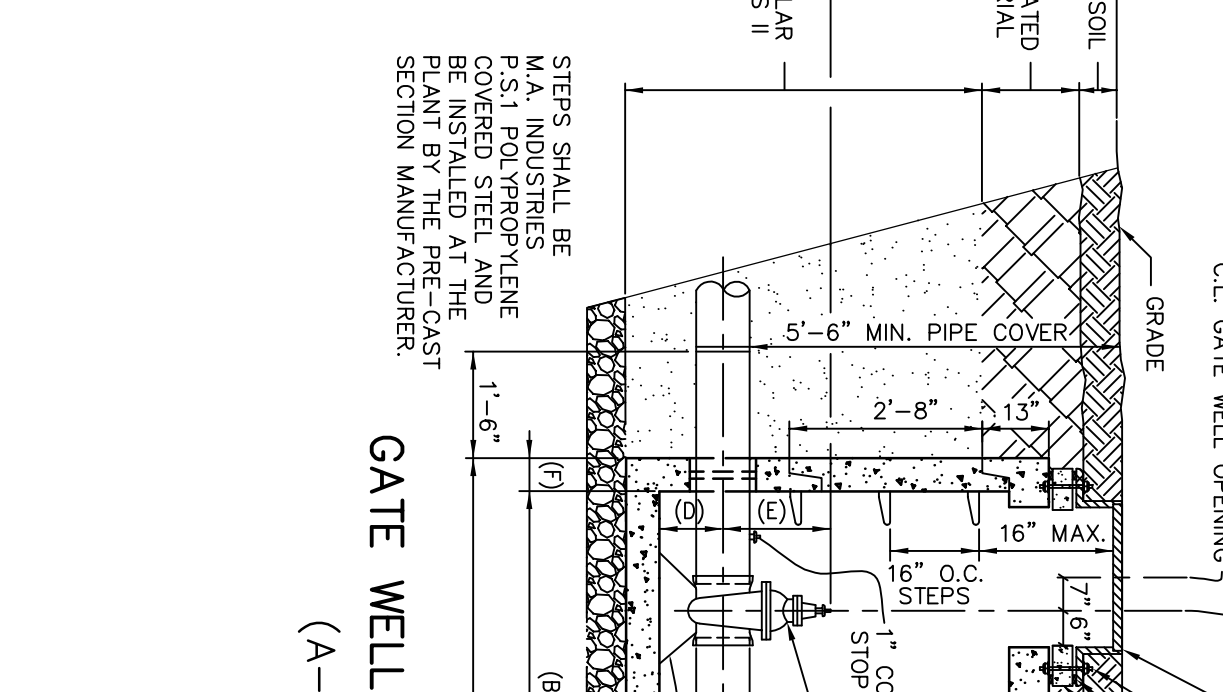
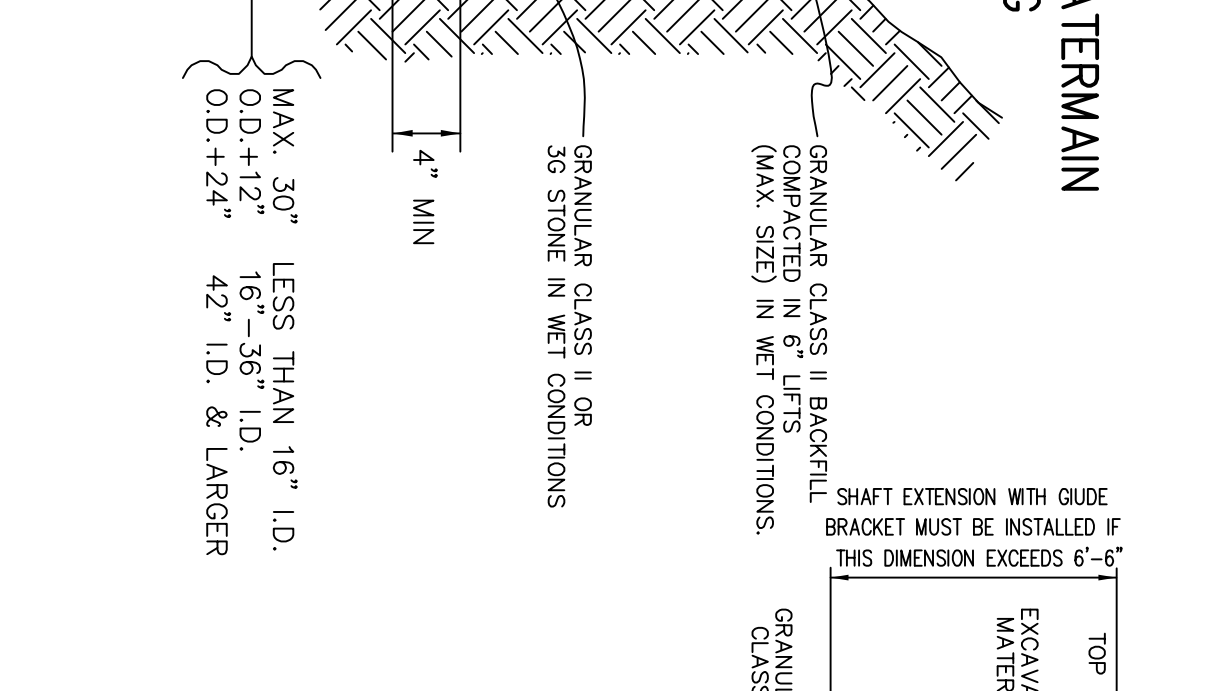
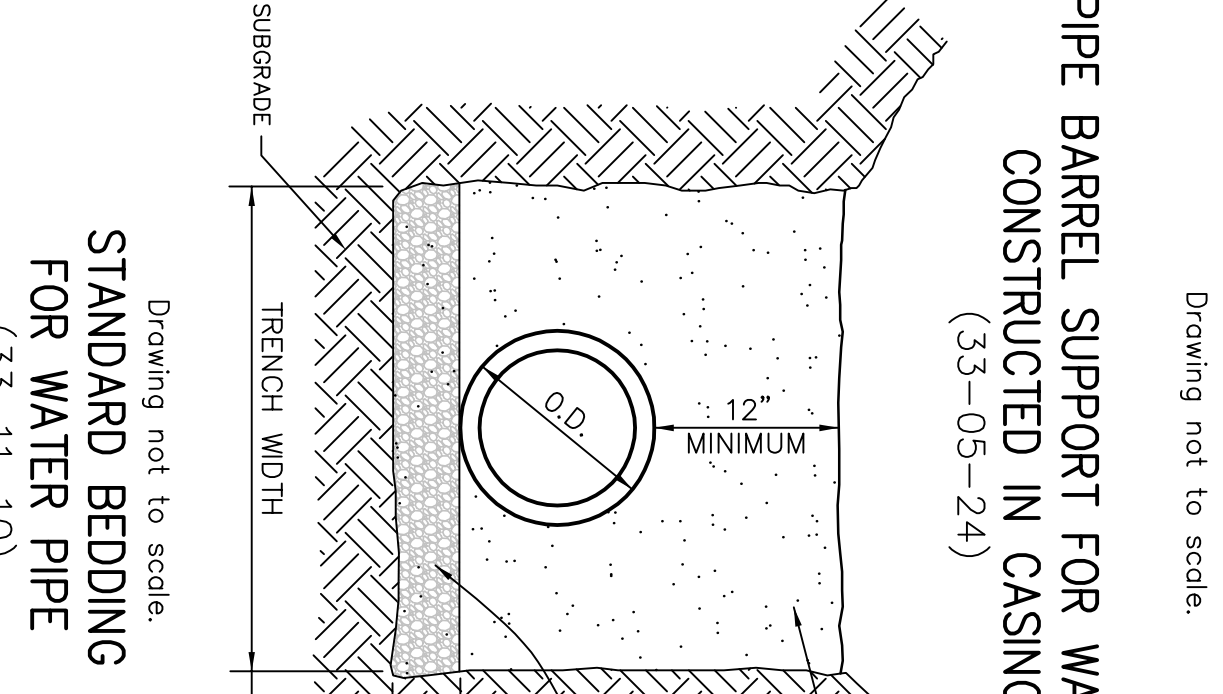

WATER MAIN CONSTRUCTION NOTES

All construction and materials shall comply with current Standards and Specifications of the Township of West Bloomfield and/or the Detroit Water & Sewerage Department as their jurisdiction may apply.

Joints shall be "Super-Bel-Tite" or "Tyton" or approved equal.

Valves and fittings shall meet West Bloomfield Township and Detroit Water & Sewerage Department current Standards and Specifications.

All hydrants shall be Meter Motor E.I.L.W. 5-AR250 Torflex-type and not self-dripping with a 6.5" bury. Hydrant drain opening shall be securely plugged.

All Gate Valves shall be E.I.L.W. Flow Master Valves.

The Contractor shall contact all utility companies for size and location of existing utilities and provisions shall be made for their protection. Contact Oakland County Utility Location and Protection Service ("ULSSINC"). The Contractor will be responsible for any and all damage to the utilities caused by his operation.

The Contractor shall, 48 hours prior to start of construction, notify the Inspection Section of the Detroit Water & Sewerage Department of (313) 224-6691, and the West Bloomfield Township Engineering Department of (248) 451-4624.

All water main construction shall have competent full-time inspection provided by, or caused to be provided by, West Bloomfield Township.

All trenches under or within 4 feet of existing or proposed paving shall be backfilled with porous Granular Class II material in 12" layers for entire depth of trench and machine tamped to 95% compaction.

Where two utilities cross, provide porous Granular Class II backfill material in 12" compacted layers to the underside of the higher utility.

New water gate well covers shall be provided with covers reading "West Bloomfield Water" in raised letters. East Jordan formwork #1040 or approved equal.

All water mains shall be constructed with a minimum cover of five and one half (5 1/2) feet below finished grades including open drainage courses.

Where water mains must dip to pass under other utilities, the sections which are deeper than normal shall be kept to a minimum length by the use of 1 1/4" vertical bends properly anchored. Vertical bends greater than 1 1/4" shall be provided with Mega-Lug or approved equal joint restraint.

Concrete thrust blocks shall be placed at all hydrants, tees, bends, and changes in direction of line of water main.

Water mains shall be pressure-tested at 150 p.s.i. for a minimum of two hours and witnessed by the Township. Taking of samples after chlorination shall be witnessed by the Township.

New water main construction to be connected to existing water system after successful completion of all tests.

The Contractor shall furnish all water used on this project, including water used for hydrostatic purposes, chlorination, and flushing. If he elects to purchase water from the Township, he must pay for the full measured amount of the current water rate for the system used. If a meter is not available to measure water volume, the Contractor shall pay for a minimum for five (5) times the volume capacity of the pipe installed, or as otherwise determined by the Township.

Air release monitors shall consist of a standard 5" diameter gate well style structure with a Valmatic Model 25C or release valve mounted on a 1" corporation stop. Air release shall be equipped with the vacuum check option. A 1/2" diameter galvanized pipe or discharge shall be extended to within 12" of the top of the structure. A goose-neck trap shall be installed at the top of the riser to prevent debris & water from entering the valve.

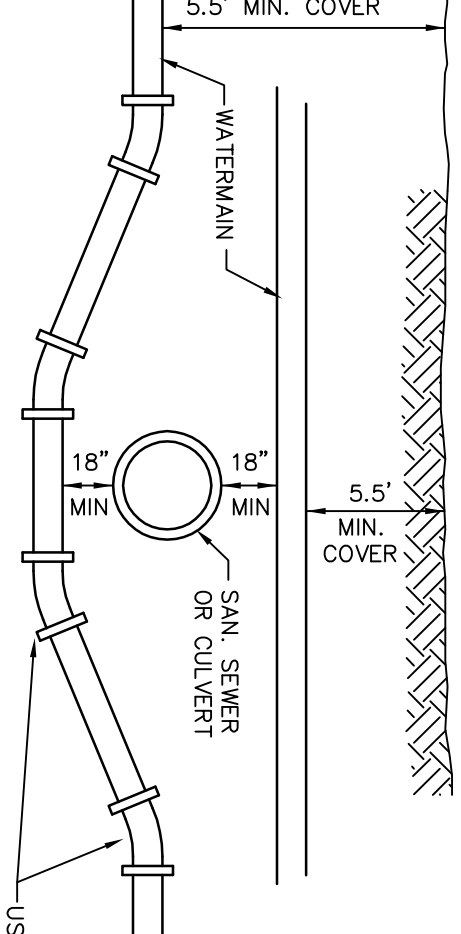

SEWER OR CULVERT CROSSING
USE 11 1/4\"/>

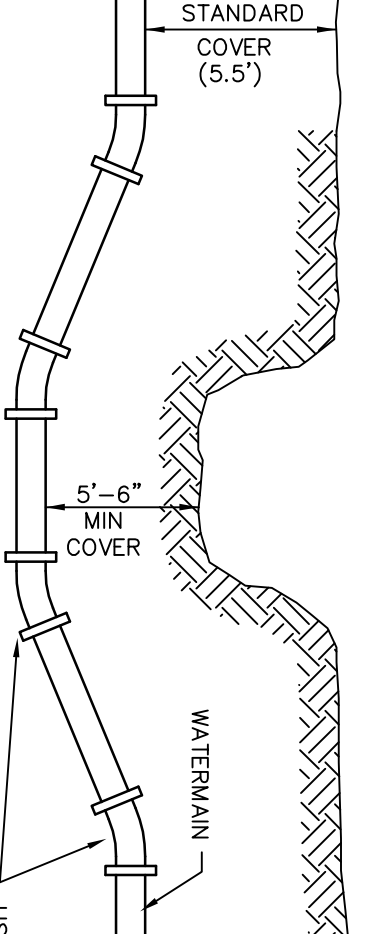

DITCH AND STREAM CROSSING
USE 11 1/4\"/>

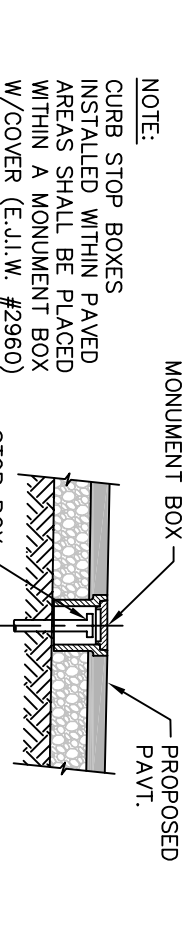

TYPICAL SINGLE FAMILY WATER SERVICE CONNECTION
(33-12-16-2)



MANDATORY HYDRANT SETTING
(33-12-16-2)



THRUST BLOCK DETAILS

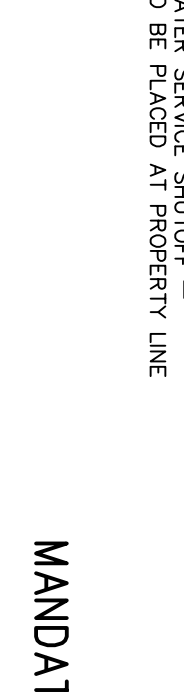

THRUST BLOCK DETAILS

FOR 90° BENDS OR SMALLER

D	A	B	C	E MIN.
24"	6'-6"	3'-6"	Z-6"	Z-6"
20"	6'-6"	3'-6"	Z-6"	Z-6"
16"	4'-4"	2'-6"	Z-6"	Z-6"
12"	4'-4"	2'-6"	Z-6"	Z-6"
8"	3'-3"	2'-6"	Z-6"	Z-6"
6"	2'-2"	1'-6"	Z-6"	Z-6"

FOR PLUGS

D	A	B	C	E MIN.
24"	7'	5'	Z-6"	Z-6"
20"	7'	5'	Z-6"	Z-6"
16"	4'-10"	4'-10"	Z-6"	Z-6"
12"	4'-4"	3'	1'-9"	1'-9"
8"	2'-10"	2'-6"	1'-9"	1'-9"
6"	1'-6"	1'-6"	3"	3"

FOR TEES

D	A	B	C	E MIN.
24"	4'-8"	3'-6"	3'	3'
20"	4'-8"	3'-6"	3'	3'
16"	4'-8"	2'-6"	2'-9"	2'-9"
12"	4'-4"	2'-6"	2'-9"	2'-9"
8"	2'-8"	2'-6"	2'-9"	2'-9"
6"	2'-2"	2'-6"	2'-9"	2'-9"

BACKFILL IN THE AREA OF STREETS, ALLEYS, SIDEWALKS, DRIVES & PARKING AREAS

NOTE: 3000 PSI CONCRETE TO BE USED. THRUST BLOCK TO ABUT & REST ON MAINLINE WATERMAIN. MAINLINE WATERMAIN SHALL BE MANDATORY BLOCK & MORTAR ON A CASE BY CASE BASIS. APPROVAL OF ENGINEERING DIVISION.

WATERMAIN STANDARD DETAILS

DATE: 7/7/09
REVISIONS: DETAIL UPDATE
DATE: 12/22/09
REVISIONS: REVISED HPI, SETTINGS DET. & NOTES
DATE: 07/25/11
REVISIONS: REVISED HPI, & OTHER NOTES

WATERMAIN STANDARD DETAILS

DATE: 4-1-07
SCALE: NONE
DRAWN BY: DSN/CK
G.N. S.T.

4550 Walnut Lake Road
West Bloomfield, Michigan 48325
Telephone 248-451-4800

SHEET No: CE-5

DATE: 4-1-07
SCALE: NONE
DRAWN BY: DSN/CK
G.N. S.T.

CHARTER TOWNSHIP OF WEST BLOOMFIELD

DATE: 7/7/09
REVISIONS: DETAIL UPDATE
DATE: 12/22/09
REVISIONS: REVISED HPI, SETTINGS DET. & NOTES
DATE: 07/25/11
REVISIONS: REVISED HPI, & OTHER NOTES

4550 Walnut Lake Road
West Bloomfield, Michigan 48325
Telephone 248-451-4800

SHEET No: CE-5

DATE: 4-1-07
SCALE: NONE
DRAWN BY: DSN/CK
G.N. S.T.

CHARTER TOWNSHIP OF WEST BLOOMFIELD

DATE: 7/7/09
REVISIONS: DETAIL UPDATE
DATE: 12/22/09
REVISIONS: REVISED HPI, SETTINGS DET. & NOTES
DATE: 07/25/11
REVISIONS: REVISED HPI, & OTHER NOTES

4550 Walnut Lake Road
West Bloomfield, Michigan 48325
Telephone 248-451-4800

SHEET No: CE-5

DATE: 4-1-07
SCALE: NONE
DRAWN BY: DSN/CK
G.N. S.T.

CHARTER TOWNSHIP OF WEST BLOOMFIELD

DATE: 7/7/09
REVISIONS: DETAIL UPDATE
DATE: 12/22/09
REVISIONS: REVISED HPI, SETTINGS DET. & NOTES
DATE: 07/25/11
REVISIONS: REVISED HPI, & OTHER NOTES

4550 Walnut Lake Road
West Bloomfield, Michigan 48325
Telephone 248-451-4800

SHEET No: CE-5

DATE: 4-1-07
SCALE: NONE
DRAWN BY: DSN/CK
G.N. S.T.

CHARTER TOWNSHIP OF WEST BLOOMFIELD

DATE: 7/7/09
REVISIONS: DETAIL UPDATE
DATE: 12/22/09
REVISIONS: REVISED HPI, SETTINGS DET. & NOTES
DATE: 07/25/11
REVISIONS: REVISED HPI, & OTHER NOTES

4550 Walnut Lake Road
West Bloomfield, Michigan 48325
Telephone 248-451-4800

SHEET No: CE-5

DATE: 4-1-07
SCALE: NONE
DRAWN BY: DSN/CK
G.N. S.T.

CHARTER TOWNSHIP OF WEST BLOOMFIELD

DATE: 7/7/09
REVISIONS: DETAIL UPDATE
DATE: 12/22/09
REVISIONS: REVISED HPI, SETTINGS DET. & NOTES
DATE: 07/25/11
REVISIONS: REVISED HPI, & OTHER NOTES

4550 Walnut Lake Road
West Bloomfield, Michigan 48325
Telephone 248-451-4800

SHEET No: CE-5

DATE: 4-1-07
SCALE: NONE
DRAWN BY: DSN/CK
G.N. S.T.

CHARTER TOWNSHIP OF WEST BLOOMFIELD

DATE: 7/7/09
REVISIONS: DETAIL UPDATE
DATE: 12/22/09
REVISIONS: REVISED HPI, SETTINGS DET. & NOTES
DATE: 07/25/11
REVISIONS: REVISED HPI, & OTHER NOTES

4550 Walnut Lake Road
West Bloomfield, Michigan 48325
Telephone 248-451-4800

SHEET No: CE-5

DATE: 4-1-07
SCALE: NONE
DRAWN BY: DSN/CK
G.N. S.T.

CHARTER TOWNSHIP OF WEST BLOOMFIELD

DATE: 7/7/09
REVISIONS: DETAIL UPDATE
DATE: 12/22/09
REVISIONS: REVISED HPI, SETTINGS DET. & NOTES
DATE: 07/25/11
REVISIONS: REVISED HPI, & OTHER NOTES

4550 Walnut Lake Road
West Bloomfield, Michigan 48325
Telephone 248-451-4800

SHEET No: CE-5

DATE: 4-1-07
SCALE: NONE
DRAWN BY: DSN/CK
G.N. S.T.

CHARTER TOWNSHIP OF WEST BLOOMFIELD

DATE: 7/7/09
REVISIONS: DETAIL UPDATE
DATE: 12/22/09
REVISIONS: REVISED HPI, SETTINGS DET. & NOTES
DATE: 07/25/11
REVISIONS: REVISED HPI, & OTHER NOTES

4550 Walnut Lake Road
West Bloomfield, Michigan 48325
Telephone 248-451-4800

SHEET No: CE-5

DATE: 4-1-07
SCALE: NONE
DRAWN BY: DSN/CK
G.N. S.T.

CHARTER TOWNSHIP OF WEST BLOOMFIELD

DATE: 7/7/09
REVISIONS: DETAIL UPDATE
DATE: 12/22/09
REVISIONS: REVISED HPI, SETTINGS DET. & NOTES
DATE: 07/25/11
REVISIONS: REVISED HPI, & OTHER NOTES

4550 Walnut Lake Road
West Bloomfield, Michigan 48325
Telephone 248-451-4800

SHEET No: CE-5

DATE: 4-1-07
SCALE: NONE
DRAWN BY: DSN/CK
G.N. S.T.

CHARTER TOWNSHIP OF WEST BLOOMFIELD

DATE: 7/7/09
REVISIONS: DETAIL UPDATE
DATE: 12/22/09
REVISIONS: REVISED HPI, SETTINGS DET. & NOTES
DATE: 07/25/11
REVISIONS: REVISED HPI, & OTHER NOTES

4550 Walnut Lake Road
West Bloomfield, Michigan 48325
Telephone 248-451-4800

SHEET No: CE-5

DATE: 4-1-07
SCALE: NONE
DRAWN BY: DSN/CK
G.N. S.T.

CHARTER TOWNSHIP OF WEST BLOOMFIELD

DATE: 7/7/09
REVISIONS: DETAIL UPDATE
DATE: 12/22/09
REVISIONS: REVISED HPI, SETTINGS DET. & NOTES
DATE: 07/25/11
REVISIONS: REVISED HPI, & OTHER NOTES

4550 Walnut Lake Road
West Bloomfield, Michigan 48325
Telephone 248-451-4800

SHEET No: CE-5

DATE: 4-1-07
SCALE: NONE
DRAWN BY: DSN/CK
G.N. S.T.

CHARTER TOWNSHIP OF WEST BLOOMFIELD

DATE: 7/7/09
REVISIONS: DETAIL UPDATE
DATE: 12/22/09
REVISIONS: REVISED HPI, SETTINGS DET. & NOTES
DATE: 07/25/11
REVISIONS: REVISED HPI, & OTHER NOTES

4550 Walnut Lake Road
West Bloomfield, Michigan 48325
Telephone 248-451-4800

SHEET No: CE-5

DATE: 4-1-07
SCALE: NONE
DRAWN BY: DSN/CK
G.N. S.T.

CHARTER TOWNSHIP OF WEST BLOOMFIELD

DATE: 7/7/09
REVISIONS: DETAIL UPDATE
DATE: 12/22/09
REVISIONS: REVISED HPI, SETTINGS DET. & NOTES
DATE: 07/25/11
REVISIONS: REVISED HPI, & OTHER NOTES

4550 Walnut Lake Road
West Bloomfield, Michigan 48325
Telephone 248-451-4800

SHEET No: CE-5

DATE: 4-1-07
SCALE: NONE
DRAWN BY: DSN/CK
G.N. S.T.

CHARTER TOWNSHIP OF WEST BLOOMFIELD

DATE: 7/7/09
REVISIONS: DETAIL UPDATE
DATE: 12/22/09
REVISIONS: REVISED HPI, SETTINGS DET. & NOTES
DATE: 07/25/11
REVISIONS: REVISED HPI, & OTHER NOTES

4550 Walnut Lake Road
West Bloomfield, Michigan 48325
Telephone 248-451-4800

SHEET No: CE-5

DATE: 4-1-07
SCALE: NONE
DRAWN BY: DSN/CK
G.N. S.T.

CHARTER TOWNSHIP OF WEST BLOOMFIELD

DATE: 7/7/09
REVISIONS: DETAIL UPDATE
DATE: 12/22/09
REVISIONS: REVISED HPI, SETTINGS DET. & NOTES
DATE: 07/25/11
REVISIONS: REVISED HPI, & OTHER NOTES

4550 Walnut Lake Road
West Bloomfield, Michigan 48325
Telephone 248-451-4800

SHEET No: CE-5

DATE: 4-1-07
SCALE: NONE
DRAWN BY: DSN/CK
G.N. S.T.

CHARTER TOWNSHIP OF WEST BLOOMFIELD

DATE: 7/7/09
REVISIONS: DETAIL UPDATE
DATE: 12/22/09
REVISIONS: REVISED HPI, SETTINGS DET. & NOTES
DATE: 07/25/11
REVISIONS: REVISED HPI, & OTHER NOTES

4550 Walnut Lake Road
West Bloomfield, Michigan 48325
Telephone 248-451-4800

SHEET No: CE-5

DATE: 4-1-07
SCALE: NONE
DRAWN BY: DSN/CK
G.N. S.T.

CHARTER TOWNSHIP OF WEST BLOOMFIELD

DATE: 7/7/09
REVISIONS: DETAIL UPDATE
DATE: 12/22/09
REVISIONS: REVISED HPI, SETTINGS DET. & NOTES
DATE: 07/25/11
REVISIONS: REVISED HPI, & OTHER NOTES

4550 Walnut Lake Road
West Bloomfield, Michigan 48325
Telephone 248-451-4800

SHEET No: CE-5

DATE: 4-1-07
SCALE: NONE
DRAWN BY: DSN/CK
G.N. S.T.

CHARTER TOWNSHIP OF WEST BLOOMFIELD

DATE: 7/7/09
REVISIONS: DETAIL UPDATE
DATE: 12/22/09
REVISIONS: REVISED HPI, SETTINGS DET. & NOTES
DATE: 07/25/11
REVISIONS: REVISED HPI, & OTHER NOTES

4550 Walnut Lake Road
West Bloomfield, Michigan 48325
Telephone 248-451-4800

SHEET No: CE-5

DATE: 4-1-07
SCALE: NONE
DRAWN BY: DSN/CK
G.N. S.T.

CHARTER TOWNSHIP OF WEST BLOOMFIELD

DATE: 7/7/09
REVISIONS: DETAIL UPDATE
DATE: 12/22/09
REVISIONS: REVISED HPI, SETTINGS DET. & NOTES
DATE: 07/25/11
REVISIONS: REVISED HPI, & OTHER NOTES

4550 Walnut Lake Road
West Bloomfield, Michigan 48325
Telephone 248-451-4800

SHEET No: CE-5

DATE: 4-1-07
SCALE: NONE
DRAWN BY: DSN/CK
G.N. S.T.

CHARTER TOWNSHIP OF WEST BLOOMFIELD

DATE: 7/7/09
REVISIONS: DETAIL UPDATE
DATE: 12/22/09
REVISIONS: REVISED HPI, SETTINGS DET. & NOTES
DATE: 07/25/11
REVISIONS: REVISED HPI, & OTHER NOTES

4550 Walnut Lake Road
West Bloomfield, Michigan 48325
Telephone 248-451-4800

SHEET No: CE-5

DATE: 4-1-07
SCALE: NONE
DRAWN BY: DSN/CK
G.N. S.T.

CHARTER TOWNSHIP OF WEST BLOOMFIELD

DATE: 7/7/09
REVISIONS: DETAIL UPDATE
DATE: 12/22/09
REVISIONS: REVISED HPI, SETTINGS DET. & NOTES
DATE: 07/25/11
REVISIONS: REVISED HPI, & OTHER NOTES

4550 Walnut Lake Road
West Bloomfield, Michigan 48325
Telephone 248-451-4800

SHEET No: CE-5

DATE: 4-1-07
SCALE: NONE
DRAWN BY: DSN/CK
G.N. S.T.

CHARTER TOWNSHIP OF WEST BLOOMFIELD

DATE: 7/7/09
REVISIONS: DETAIL UPDATE
DATE: 12/22/09
REVISIONS: REVISED HPI, SETTINGS DET. & NOTES
DATE: 07/25/11
REVISIONS: REVISED HPI, & OTHER NOTES

4550 Walnut Lake Road
West Bloomfield, Michigan 48325
Telephone 248-451-4800

SHEET No: CE-5

DATE: 4-1-07
SCALE: NONE
DRAWN BY: DSN/CK
G.N. S.T.

CHARTER TOWNSHIP OF WEST BLOOMFIELD

DATE: 7/7/09
REVISION